

Why Are Buyouts Levered? The Financial Structure of Private Equity Funds

ULF AXELSON, PER STRÖMBERG, and MICHAEL S. WEISBACH*

ABSTRACT

Private equity funds are important to the economy, yet there is little analysis explaining their financial structure. In our model the financial structure minimizes agency conflicts between fund managers and investors. Relative to financing each deal separately, raising a fund where the manager receives a fraction of aggregate excess returns reduces incentives to make bad investments. Efficiency is further improved by requiring funds to also use deal-by-deal debt financing, which becomes unavailable in states where internal discipline fails. Private equity investment becomes highly sensitive to aggregate credit conditions and investments in bad states outperform investments in good states.

Practitioner: "Things are really tough because the banks are only lending four times cash flow, when they used to lend six times cash flow. We can't make our deals profitable anymore."

Academic: "Why do you care if banks will not lend you as much as they used to? If you are unable to lever up as much as before, your limited partners will receive lower expected returns on any given deal, but the risk to them will have gone down proportionately."

Practitioner: "Ah yes, the Modigliani-Miller theorem. I learned about that in business school. We don't think that way at our firm. Our philosophy is to lever our deals as much as we can, to give the highest returns to our limited partners."

PRIVATE EQUITY FUNDS are responsible for an enormous quantity of investment in the economy. From 2005 to June 2007, CapitalIQ recorded a total of 5,188 buyout

*Ulf Axelson is with the Stockholm School of Economics and SIFR. Per Strömberg is with the Stockholm School of Economics, SIFR, CEPR, and NBER. Michael S. Weisbach is with Ohio State University and NBER. We would like to thank an anonymous referee, Diego Garcia, Campbell Harvey (the editor), Bengt Holmström, Antoinette Schoar, and Jeremy Stein (the associate editor) for helpful comments, and seminar participants at University of Amsterdam, UC Berkeley, Boston College, CEPR Summer Institute 2005, University of Chicago, ECB-CFS, Emory University, Harvard University, Helsinki School of Economics, HKUST, University of Illinois at Urbana-Champaign, INSEAD, MIT, NBER 2005, Norwegian School of Economics, NYU, Oxford University, Paris-Dauphine University, Rutgers University, SSE Riga, Stockholm School of Economics, University of Texas, Vanderbilt University, Stockholm University, University of Virginia, Washington University, and WFA Meetings 2005.

transactions at a combined estimated enterprise value of over \$1.6 trillion (Kaplan and Strömberg (2009)). Private equity investments are also of major importance not just in the United States, but internationally as well; for example, over the same 2005 to June 2007 period, North America only accounted for 47% of the value of buyout transactions. In addition, private equity funds are active not only in buyouts but in a variety of other types of investments, such as providing venture capital to start-ups and investing in real estate and infrastructure. Yet, while a massive literature explores the financing of corporate investments, very little work has been done on the financing of the increasingly important investments of private equity funds.

Private equity investments are generally made by funds that share a common organizational structure (see Sahlman (1990) or Fenn, Liang, and Prowse (1997) for more discussion). Typically, these funds raise equity at the time they are formed, and raise additional capital when investments are made. This additional capital usually takes the form of debt when the investment is collateralizable, such as in buyouts, or equity from syndication partners when it is not, as in a startup. The funds are usually organized as limited partnerships, with the limited partners (LPs) providing most of the capital and the general partners (GPs) making investment decisions and receiving a substantial share of the profits (most often 20%). While the literature has spent much effort to shed light on some aspects of the private equity market, there are no clear answers to the basic questions of why funds choose this financial structure, and what the impact of this structure is on funds' investment choices and performance. Why is most private equity activity undertaken by funds where LPs commit capital for a number of investments over the fund's life? Why are the equity investments of these funds complemented by deal-level financing from third parties? Why do GP compensation contracts have the nonlinear incentive structure commonly observed in practice? What should we expect to observe about the relation between industry cycles, bank lending practices, and the prices and returns of private equity investments? Why are booms and busts in the private equity industry so prevalent?

In this paper, we propose a new explanation for the financial structure of private equity firms based on a simple agency conflict between the private equity fund managers and their investors. General partners have skill in identifying and managing potentially profitable investments, but have to rely on external capital provided by limited partners to finance these investments. Because GPs have limited liability and hence take less of the downside risk in any deal, they have an incentive to overstate the quality of potential investments when they try to raise financing from uninformed investors, as in Myers and Majluf (1984). In contrast to standard static adverse selection settings, we assume that the GP faces two potential investment objects over time that require financing. In particular, we consider regimes in which the GP raises capital on a deal-by-deal basis (ex post financing), raises a fund that can completely finance a number of future projects (ex ante financing), or employs a combination of the two types of financing.

With ex post financing, the solution is the same as in the static adverse selection model. Debt will be the optimal security, and GPs will choose to undertake all investments they can get financing for, even if those investments are value-decreasing. Whether deals will be financed at all depends on the state of the economy—in good times, where the average project is positive net present value (NPV), there is overinvestment, and in bad times there is underinvestment.

Ex ante financing can alleviate some of these problems. By tying the compensation of the GP to the collective performance of a fund, the GP has less of an incentive to invest in bad deals, since bad deals will contaminate his stake in the good deals. Thus, a fund structure often dominates deal-by-deal capital raising. Furthermore, debt is typically not the optimal security for a fund. Issuing debt will maximize the risk-shifting tendencies of a GP since it leaves him with a call option on the fund. We show that, instead, it is optimal to design a contract giving investors a debt claim plus a levered equity stake, leaving the GP with a “carry” at the fund level that resembles contracts observed in practice.

The downside of pure ex ante capital raising is that it leaves the GP with substantial freedom. Once the fund is raised he does not have to go back to the capital markets, and thus he can fund deals even in bad times. If the GP has not encountered enough good projects and is approaching the end of the investment horizon, or if economic conditions shift so that not many good deals are expected to arrive in the future, a GP with untapped funds has the incentive to “go for broke” and take bad deals.

We show that it is therefore typically optimal to use a mix of ex ante and ex post capital. Giving the GP some capital ex ante preserves his incentives to avoid bad deals in good times, but adding the ex post component has the effect of preventing the GP from being able to invest in bad deals in bad times. This financing structure turns out to be optimal in the sense that it maximizes the value of investments by minimizing the expected value of negative NPV investments undertaken and good investments ignored. In addition, the structure of the securities in the optimal financing structure mirrors common practice; ex post deal funding is done with risky debt that has to be raised from third parties such as banks, the LP’s claim is senior to the GP’s, and the GP’s claim is a fraction of the profits.

Even with this optimal financing structure, investment nonetheless deviates from its first-best level. During recessions, there will not only be fewer valuable investment opportunities, but those that do exist will have difficulty being financed. Similarly, during boom times, not only will there be more good projects than in bad times, but bad projects will be financed in addition to the good ones. This investment pattern provides an explanation for the common observation that the private equity investment process is procyclical (see Gompers and Lerner (1999b)). It is also consistent with the observation that private equity activity is highly correlated with the liquidity in the market for corporate debt (see Axelson et al. (2008) and Kaplan and Strömberg (2009)). Finally, it suggests that there is some validity to the common

complaint from GPs that during tough times it is difficult to get financing for even very good projects, while during good times many poor projects get financed.

An important empirical implication of this result is that returns to investments made during booms will be lower on average than the returns to investments made during poor times. This finding is consistent with anecdotal evidence about poor investments made during the internet and biotech bubbles, as well as some of the most successful deals being initiated during busts. Academic studies have also found evidence that suggests such countercyclical investment performance in both the buyout (Kaplan and Stein (1993)) and the venture capital markets (Gompers and Lerner (2000)).

Our paper relates to a theoretical literature that analyzes the effect of pooling on investment incentives and optimal contracting. Diamond (1984) shows that by changing the cash flow distribution, investment pooling makes it possible to design contracts that incentivize the agent to monitor the investments properly. Bolton and Scharfstein (1990) and Laux (2001) show that tying investment decisions together can create “inside wealth” for the agent undertaking the investments, which reduces the limited liability constraint and helps design more efficient contracts. Unlike our model, neither of these papers considers project choice under adverse selection, nor do they have any role for outside equity in the optimal contract. Our paper also relates to an emerging literature analyzing private equity fund structures. Jones and Rhodes-Kropf (2003) and Kandel, Leshchinskii, and Yulea (2006) also argue that fund structures can lead GPs to make inefficient investments in risky projects. Unlike our paper, however, these papers take fund structures as given and do not derive investment incentives resulting from an optimal contract. Inderst, Mueller, and Münnich (2007) argue that pooling private equity investments together in a fund helps the GP commit to efficient liquidation decisions, in a way similar to the winner-picking model of Stein (1997). Their mechanism relies on always making the fund capital-constrained, which we show is not optimal in our model. Most importantly, none of the previous theoretical papers analyze the interplay of ex ante pooled financing and ex post deal-by-deal financing, which lies at the heart of our model.

The remainder of the paper is structured as follows. Section I outlines the model. Sections II and III describe the solution to the financing problem under two extreme capital raising scenarios: when all capital is raised as deals are encountered (pure ex post financing: Section II), and when all capital is raised ex ante (Section III). Section IV characterizes the optimal solution, which turns out to comprise a combination of ex ante and ex post financing. Section V discusses implications of the model, and Section VI concludes.

I. Model

There are three types of agents in the model: general partners (GPs), limited partners (LPs), and fly-by-night operators. All agents are risk-neutral and have

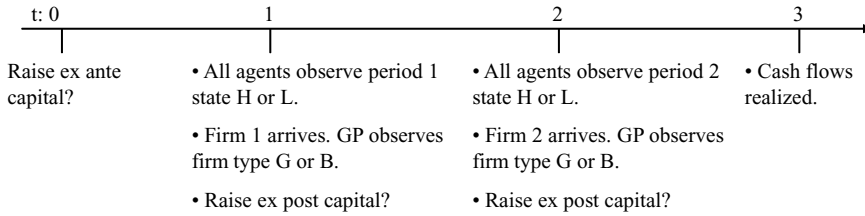

Figure 1. Timeline.

access to a storage technology yielding the risk-free rate, which we assume to be zero.¹

The timing of the model is summarized in Figure 1. There are two periods. Each period a candidate firm arrives. We assume it costs I for the private equity fund to invest in a firm. Firms are of two kinds: good (G) and bad (B). The quality of the firm is only observed by the GP. A good firm has cash flow $Z > 0$ with certainty and a bad firm has cash flow 0 with probability $1 - p$ and cash flow Z with probability p , where

$$Z > I > pZ,$$

so that good firms are positive NPV and bad firms are negative NPV investments. All cash flows are realized at the end of period 2, so there is no early information available about investment performance.

Each period a good firm arrives with probability α and a bad firm with probability $1 - \alpha$.² We think of α as representing the common perception of the quality of the type of deals associated with the specialty of the GP that are available at a point in time. To facilitate the analysis, we assume there are only two possible values for α : α_H , which occurs with probability q each period, and α_L , which occurs with probability $1 - q$ each period. Also, we assume $\alpha_H > \alpha_L$. To capture the notion that α stands for possibly unmeasurable perceptions in the marketplace, we assume it is observable but not verifiable, so it cannot be contracted on directly. However, the period 2 cash flows of each investment are contractable.

¹ Although risk neutrality may be a bad assumption for a GP who has a large undiversified exposure to the payoff of the fund, we believe that the qualitative nature of the results would largely be the same even if we assumed that the GP was risk-averse. We conjecture that the details of the solution would change mainly along two dimensions: First, the pure ex post financing solution outlined in Section II would become even less appealing relative to the pure ex ante financing solution in Section III, as the GP compensation is more volatile with pure ex post financing. Second, the exact shape of securities might be altered; when the GP is risk-averse, there is an extra incentive to reduce the risk of his compensation. For example, in the pure ex post financing case, debt may no longer be the optimal security. In the pure ex ante and mixed financing cases, the GP carry might become more concave, although there is a limit to how safe you can make the GP stake without destroying his incentives to invest in valuable but risky projects.

² Equivalently, we can assume that there are always bad firms available, and a good firm arrives with probability α .

The assumptions of a finitely lived economy and of separately contractable cash flows from each investment are what makes this a model of private equity rather than a model of a standard corporation facing a series of investments. The usual structure in the private equity industry is to have finitely lived funds, while standard firms have indefinite lives. The assumption that cash flows are separately contractable is critical for the results of the model, but is unlikely to be realistic for a standard corporation in which different investments rely on common resources. Nevertheless, we speculate in Section V on how the model's insights can help explain financial structures of standard corporations, and provide suggestions for why finitely lived structures are more likely to occur in private equity funds than in standard firms.

We assume the GP has no money of his own and finances his investments by issuing a security $w_I(x)$ backed by the cash flow x from the investments, and keeps the residual security $w_{GP}(x) = x - w_I(x)$. If the GP had sufficient resources, the agency problems would be alleviated since he could finance part of the investments himself. As long as the GP cannot finance such a large part of the investments that the agency problems completely disappear, allowing for GP wealth does not change the qualitative nature of our results.³

The securities have to satisfy the following monotonicity condition:

MONOTONICITY: $w_I(x)$ and $w_{GP}(x)$ are nondecreasing.

This assumption is standard in the security design literature and can be formally justified on grounds of moral hazard.⁴ An equivalent way of expressing the monotonicity condition is

$$x - x' \geq w_{GP}(x) - w_{GP}(x') \geq 0, \quad \forall x, x' \text{ s.t. } x > x'.$$

Furthermore, we assume that contracts cannot be such that the GP can earn money by passive strategies such as storing the capital at the riskless rate, or buying and holding publicly traded, fairly priced assets such as stocks or options. If GPs could raise capital with such contracts, we assume that the market would be swamped by an infinite supply of unskilled fly-by-night operators that investors cannot distinguish from a serious GP. Fly-by-night operators can only find real investments that have a maximum payoff less than capital invested, store money at the riskless rate, or invest in a fairly priced publicly traded asset (so that the investment has a zero NPV). Thus, they add no value. Since the supply of fly-by-night operators is potentially infinite, there cannot be an equilibrium where fly-by-night operators earn positive rents and investors

³ In practice, GPs are typically required to contribute at least 1% of the partnership's capital personally.

⁴ See, e.g., Innes (1990). Suppose an investor claim $w(x)$ is decreasing on a region $a < x < b$, and that the underlying cash flow turns out to be a . The GP then has an incentive to secretly borrow money from a third party and add it on to the aggregate cash flow to push it into the decreasing region, thereby reducing the payment to the security holder while still being able to pay back the third party. Similarly, if the GP's retained claim is decreasing over some region $a < x \leq b$ and the realized cash flow is b , the GP has an incentive to decrease the observed cash flow by burning money.

simultaneously break even. To make financing possible in the presence of fly-by-night operators, we assume that trading in public assets is prohibited. In addition, we assume that a GP cannot be contractually stopped from storing capital at the risk-free rate, but the payoff to the GP if he stores the capital has to be zero.

FLY-BY-NIGHT: For invested capital K , $w_{GP}(x) = 0$ whenever $x \leq K$.

The assumption about fly-by-night operators is important for our results as it forces the GP payoff to be convex for low cash flow realizations. This convexity creates the risk-shifting incentives that critically drive our security design results. Although the fly-by-night problem seems most relevant when GPs with unknown track records approach investors for financing, we think similar problems apply to more established GPs as well. For example, even experienced GPs have capacity constraints in terms of how many investment objects they can seriously evaluate. If GPs are able to raise money at terms in which they get a payoff even with passive strategies, they would have an incentive to expand the fund infinitely. Alternatively, investors may be worried that an experienced GP might suddenly lose his ability. Yet another way to interpret the fly-by-night condition is as a reduced form of a moral hazard problem. If GPs have to expend costly effort to find profitable investments or to monitor them once the money is invested, convex payoffs will typically improve the GPs' incentives.

A. Forms of Capital Raising

In a first-best world, the GP will invest in all good firms and no bad firms. Because the LP has less information than the GP about firm quality, the first best will not be achievable—as we will see, adverse selection problems will typically lead to overinvestment in bad projects and underinvestment in good projects. Our objective is to find a method of capital raising that minimizes these inefficiencies. We will look at three forms of capital raising:

- *Pure ex post* capital raising is done in each period after the GP encounters a firm. The securities investors get are backed by each individual investment's cash flow.
- *Pure ex ante* capital raising is done in period 0 before the GP encounters any firm. The security investors get is backed by the sum of the cash flows from the investments in both periods.
- *Ex ante and ex post* capital raising combines the forms above. Investors supplying ex post capital in a period get a security backed by the cash flow from the investment in that period only. Investors supplying ex ante capital get a security backed by the cash flows from both investments combined.

We now analyze and compare each of the financing arrangements above.⁵

⁵This is not an exhaustive list of financing methods. We briefly discuss slightly different forms below as well, such as raising ex ante capital for only one period, raising only one unit of capital

II. Pure Ex Post Capital Raising

We first characterize the pure ex post capital raising solution. We start by analyzing the simpler static problem in which the world ends after one period, and then show that the one-period solution is also an equilibrium period-by-period in the dynamic problem.

In a one-period problem, the timing is as follows: After observing the quality of the firm, the GP decides whether to seek financing. After raising capital, he decides whether to invest in the firm or in the riskless asset.

With ex post financing the GP will have an incentive to seek financing regardless of the observed quality of the potential investment, since he receives nothing otherwise. To invest, the GP must raise I by issuing a security $w_I(x)$ to invest in a firm, where $x \in 0, I, Z$. From the fly-by-night condition, the security design has to have $w_I(I) = I$. Thus, debt with face value F such that $Z \geq F \geq I$ is the only possible security. But this in turn implies that the GP will invest in both bad and good firms whenever he can raise capital, since his payoff is zero if he invests in the riskless asset. There is no way for a GP with a good firm to separate himself from a GP with a bad firm, so the only equilibrium is a pooling one in which all GPs issue the same security.

The debt pays off only if $x = Z$, so the break-even condition for investors after learning the expected fraction of good firms α in the period is

$$(\alpha + (1 - \alpha)p)F \geq I.$$

Thus, financing is feasible as long as

$$(\alpha + (1 - \alpha)p)Z \geq I,$$

in which case the GP will invest in all firms. When it is impossible to satisfy the break-even condition, the GP cannot invest in any firms.

To make the problem interesting we assume that the unconditional probability of success is too low for investors to break even:

CONDITION 1: $(E(\alpha) + (1 - E(\alpha))p)Z < I$.

Condition 1 implies that ex post financing is not possible in the low state. Whether pure ex post financing is possible in the high state depends on whether $(\alpha_H + (1 - \alpha_H)p)Z \geq I$ holds.

The two-period problem is somewhat more complicated, as the observed investment behavior in period 1 can change investors' belief about whether a GP is a fly-by-night operator, which in turn affects the financing equilibrium in period 2.⁶ We show, however, that a repeated version of the one-period problem is the only equilibrium in which financing is possible:⁷

for the two periods, and allowing for ex post securities to be backed by more than one deal. None of these other methods improve efficiency over the ones we analyze in more detail.

⁶ After period 1, investors can observe whether the GP tried to raise financing or not, and whether he invested in the riskless asset or not. However, they cannot observe the return on any investment until the end of period 2.

⁷ The equilibrium concept we use is Bayesian Nash, together with the requirement that the equilibrium satisfy the "Intuitive Criterion" of Cho and Kreps (1987).

		<u>$(\alpha_H + (1 - \alpha_H)p)Z > I$</u>		<u>$(\alpha_H + (1 - \alpha_H)p)Z < I$</u>	
		<u>State</u>		<u>State</u>	
		High	Low	High	Low
<u>Firm</u>	Good	X	O	Good	O
	Bad	X	O	Bad	O

Figure 2. Investment behavior in the pure ex post financing case. X denotes that an investment is made, and O that no investment is made.

PROPOSITION 1: *Pure ex post financing is never feasible in the low state. If*

$$(\alpha_H + (1 - \alpha_H)p)Z \geq I$$

it is feasible in the high state, where the GP issues debt with face value F given by

$$F = \frac{I}{\alpha_H + (1 - \alpha_H)p}.$$

Proof: See Internet Appendix at <http://www.afajof.org/supplements.asp>.⁸

In the solution discussed above, fly-by-night operators earn nothing by raising financing and investing, and therefore stay out of the market.⁹

A. Efficiency

The investment behavior with pure ex post financing is illustrated in Figure 2. Investment is inefficient in both high and low states. There is always underinvestment in the low state since good deals cannot get financed. In the high state, there is underinvestment if the break-even condition of investors

⁸ An Internet Appendix for this article is online in the “Supplements and Datasets” section at <http://www.afajof.org/supplements.asp>.

⁹ We could also have imagined period-by-period financing where the security is issued after the state of the economy is realized, but *before* the GP knows what type of firm he will encounter in the period. In a one-period problem, the solution would be the same. However, one can show that if there is more than one period, the market for financing would completely break down. This is because if there is a financing equilibrium where fly-by-night operators are screened out in the first period, it is optimal for the GP to issue straight equity and avoid risk-shifting in the second period. But straight equity leaves rents to fly-by-night operators, who therefore would profit from mimicking serious GPs in earlier periods by investing in wasteful projects. Therefore, it is impossible to screen them out of the market in early periods, so there cannot be any financing at all.

cannot be met, and overinvestment otherwise, since bad deals will then get financed.

III. Pure Ex Ante Capital Raising

We now study the polar case where the GP raises all the capital to be used over the two periods for investment ex ante, before the state of the economy is realized. Hence, the GP raises $2I$ of ex ante capital in period 0, which implies that the GP is not capital-constrained and can potentially invest in both periods.¹⁰

We solve for the GP's security $w_{GP}(x) = x - w_I(x)$ that maximizes investment efficiency. For all monotonic stakes, the GP will invest in all good firms he encounters over the two periods. Also, if no investment was made in period 1, he will invest in a bad firm in period 2 rather than put the money in the riskless asset. This follows from the fly-by-night condition, since the GP's payoff has to be zero when fund cash flows are less than or equal to the capital invested.

We show that it is possible to design $w_{GP}(x)$ so that the GP avoids all other inefficiencies. Under this second-best contract, he avoids bad firms in period 1, and avoids bad firms in period 2 as long as an investment took place in period 1.

To solve for the optimal security, we maximize the GP's payoff subject to the monotonicity, fly-by-night, and investor break-even conditions, and make sure that the second-best investment behavior is incentive compatible. The security payoffs $w_{GP}(x)$ must be defined over the following potential fund cash flows: $x \in \{0, I, 2I, Z, Z + I, 2Z\}$.¹¹ The fly-by-night condition immediately implies that $w_{GP}(x) = 0$ for $x \leq 2I$.

The full maximization problem can be expressed as

$$\max_{w_{GP}(x)} E(w_{GP}(x)) = E(\alpha)^2 w_{GP}(2Z) + (2E(\alpha)(1 - E(\alpha)) + (1 - E(\alpha))^2 p) w_{GP}(Z + I),$$

such that

$$E(x - w_{GP}(x)) \geq 2I \tag{BE}$$

$$(E(\alpha) + (1 - E(\alpha))p) w_{GP}(Z + I) \geq ((1 - p)E(\alpha) + 2p(1 - p)(1 - E(\alpha))) w_{GP}(Z) + p(E(\alpha) + (1 - E(\alpha))p) w_{GP}(2Z) \tag{IC}$$

$$x - x' \geq w_{GP}(x) - w_{GP}(x') \geq 0 \quad \forall x, x' \text{ s.t. } x > x' \tag{M}$$

$$w_{GP}(x) = 0 \quad \forall x \text{ s.t. } x \leq 2I. \tag{Fly-by-night}$$

¹⁰ Later we show that in the pure ex ante case, it is never optimal to make the GP capital-constrained by giving him less than $2I$.

¹¹ Note that under a second-best contract, $x \in \{0, 2I, Z\}$ will never occur. These cash flows would result from the cases of two failed investments, no investment, and one failed and one successful investment, respectively, neither of which can result from the GP's optimal investment strategy. We still need to define security payoffs for these cash flow outcomes to ensure that the contract is incentive compatible.

There are two possible payoffs to the GP in the maximand. The first payoff, $w_{GP}(2Z)$, occurs only when good firms are encountered in both periods. The second payoff, $w_{GP}(Z + I)$, will occur either (1) when one good firm is encountered in the first or second period, or (2) when no good firm is encountered in any of the two periods, the GP invests in a bad firm in period 2, and this investment turns out to be successful.

Condition (BE) is the investor’s break-even condition. Condition (IC) is the GP’s incentive compatibility constraint, which ensures that the GP follows the prescribed investment behavior. The left-hand side is the expected payoff for a GP who encounters a bad firm in period 1 but passes it up, and then invests in any firm that appears in period 2. The right-hand side is the expected payoff if he invests in the bad firm in period 1, and then invests in any firm in period 2. When condition (IC) holds, the GP will never invest in a bad firm in period 1.¹² For incentive compatibility, we also need to ensure that the GP does not invest in a bad firm in period 2 after investing in a good firm in period 1. As we show in the proof of Proposition 2 later, this turns out to be the case whenever condition (IC) is satisfied.

Finally, the maximization has to satisfy the monotonicity (*M*) and the fly-by-night conditions. The feasible set and the optimal security design that solves this program is characterized in the following proposition:

PROPOSITION 2: *Pure ex ante financing is feasible if and only if it creates social surplus. An optimal investor security $w_I(x)$ (which is not always unique) is given by*

$$w_I(x) = \begin{cases} \min(x, F) & x \leq Z + I \\ F + k(x - (Z + I)) & x > Z + I, \end{cases}$$

where $F \geq 2I$ and $k \in (0, 1]$.

Proof: See Appendix.

Figure 3 shows the form of the optimal securities for different levels of social surplus created, where a lower surplus will imply that a higher fraction of fund cash flows has to be pledged to investors. The security structure resembles the structure in private equity funds, where investors receive all cash flows below their invested amount and a proportion of the cash flows above that. Moreover, as is shown in the proof, the contracts tend to have an intermediate region, where all the additional cash flows are given to the GP. This could be interpreted as the so-called “carry catch-up,” which is a common feature in private equity partnership agreements (see Metrick and Yasuda (2009)).

The intuition for the pure ex ante contract is as follows. Ideally, we would like to give the GP a straight equity claim, as this would assure that he only

¹² It could be the case that if the GP invests in a bad firm in period 1, he would prefer to pass up a bad firm encountered in period 2. For incentive compatibility, it is necessary to ensure that the GP gets a higher payoff when avoiding a bad period 1 firm also in this case. As we show in the proof of Proposition 2, condition (IC) implies that this is the case.

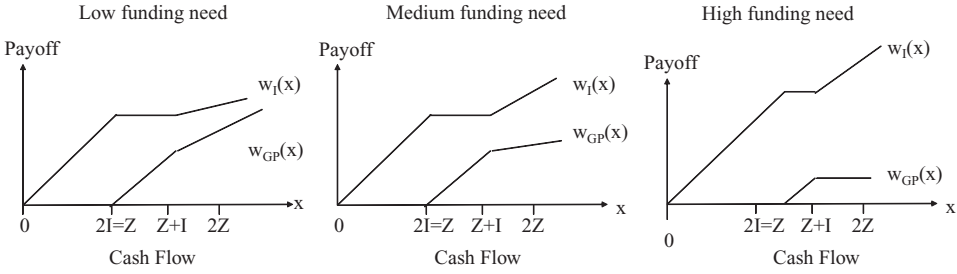

Figure 3. GP Securities ($w_{GP}(x)$) and investor securities ($w_I(x)$) as a function of fund cash flow x in the pure ex ante case. The three graphs depict contracts under high (left graph), medium (middle graph), and low (right graph) levels of $E(\alpha)$. A high level of $E(\alpha)$ corresponds to high social surplus created, which in turn means that a lower fraction of fund cash flows has to be pledged to investors.

makes positive NPV investments (i.e., invests in good firms) and otherwise invests in the risk-free asset. The problem with straight equity is that the GP receives a positive payoff even when no capital is invested, which in turn implies that unskilled fly-by-night operators can make money. If contracts are to be structured so that fly-by-night operators cannot make positive profits, GPs can only be paid if the fund cash flows are sufficiently high, which introduces a risk-shifting incentive. The risk-shifting problem is most severe if investors hold debt and the GP holds a levered equity claim on the fund cash flows. To mitigate this effect, we reduce the levered equity claim of the GP by giving a fraction of the high cash flows to investors.¹³

When the funding need is higher so that investors have to be given more rents in order to satisfy their break-even constraint, it is optimal to increase the payoff to investors for the highest cash flow states ($2Z$) first, while keeping the payoffs to GPs for the intermediate cash flow states ($Z + I$) as high as possible, in order to reduce risk-shifting incentives.¹⁴

A. Efficiency

The investment behavior in the pure ex ante relative to the pure ex post case is illustrated in Figure 4. In the ex ante case, the GP invests efficiently in period 1. If he invested in a good firm period 1, investment will be efficient in period 2 as well. The only remaining inefficiency is that the GP will invest in the bad firm in period 2 if he has not encountered any good firm in either period.

The ex ante fund structure can improve incentives relative to the ex post deal-by-deal structure by tying the payoff of several investments together and

¹³ This is similar to the classic intuition of Jensen and Meckling (1976).

¹⁴ This concavity of the GP payoff at the top of the cash flow distribution is not a robust result, but rather a result of our assumption that good projects are risk-free, so that avoiding risk is equivalent to making the efficient investment decision. If good firms had risk, the GP payoff should be made more linear at the top of the cash flow distribution to induce efficient investment behavior.

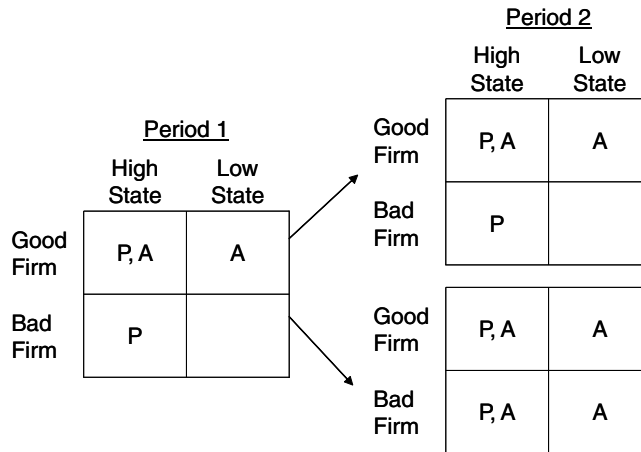

Figure 4. Investment behavior in the pure ex ante (A) compared to the pure ex post (P) case when ex post financing is possible in the high state.

structuring the GP security appropriately. In the ex post case, the investment inefficiency is caused by the inability to prevent GPs finding bad firms from seeking financing and investing. In the ex ante case, the GP can now be compensated for investing in the riskless asset rather than a bad firm as long as there is a possibility of finding a good firm. By giving the GP a stake that resembles straight equity for cash flows above the invested amount, he will make efficient investment decisions as long as he anticipates being “in the money.” Tying payoffs of past and future investments together is a way to create inside wealth endogenously and to circumvent the problems created by limited liability.

However, it is clear from Figure 4 that pure ex ante capital raising does not always dominate pure ex post capital raising. Ex post financing has the disadvantage that the GP will always invest in any firm he encounters in high states. Potentially offsetting this disadvantage is a benefit of ex post financing—since the contract will be agreed to at the time of the financing, it will be contingent on the realized value of α . Since the market is unlikely to fund projects when the economy is bad, ex post financing implicitly commits the GP not to make any investments in low states.

If low states are very unlikely to have good projects (α_L close to zero) and high states have almost only good projects (α_H close to one) investment inefficiencies with ex post fund raising will be relatively small compared with those of pure ex ante financing. In contrast, when the correlation between states and project quality is weaker, pure ex ante financing potentially leads to superior investments than pure ex post financing.

Even when pure ex ante financing is more efficient, it may still not be privately optimal for the GP to use. This is because the ex ante financing contract must be structured so that the LPs get some of the upside for the GP to follow

the right investment strategy, which sometimes will leave the LPs with strictly positive rents:

PROPOSITION 3: *In the pure ex ante financing solution, the LP sometimes earns positive rents.*

Proof: See Internet Appendix.

This result may shed some light on the puzzling finding in Kaplan and Schoar (2004) that successful GPs seem not to increase their fees in follow-up funds enough to force LPs down to a competitive rent, but rather ration the amount LPs get to invest in the fund.

We have restricted the analysis of pure ex ante financing to the case where the GP raises enough capital to finance all investments. We could also have considered a structure where the GP only raises enough funds to invest in one firm over the two periods. It is easy to see that this type of financing would lead to a less efficient solution. The GP would pass up bad firms in period 1 in the hope of finding a good firm in period 2, but there is no way of preventing him from investing in a bad firm in period 2. Therefore, the period 2 overinvestment inefficiency is the same as in the unconstrained case. In addition, there is also the additional inefficiency that if the GP encounters two good firms, he will have to pass up the last one because of a lack of financing. Thus, it is never optimal to make the GP capital-constrained in the pure ex ante setting.¹⁵ However, as we now show, it can be optimal to do so when we combine ex ante and ex post capital.

IV. Mixed Ex Ante and Ex Post Capital Raising

We now examine the case in which managers can use a combination of ex post and ex ante capital raising, and show that this is more efficient than any other type of financing. In particular, if the GP has less than $2I$ ex ante and has to raise the remainder of the funds ex post, there will be less inefficient investment in poor quality states than with pure ex ante financing.

To this end, we now assume that the GP raises $2K < 2I$ of ex ante fund capital in period 0, and is only allowed to use K for investments each period.¹⁶ The remaining $I - K$ has to be raised ex post. As we discuss later, it turns out to be critical that ex post investors are distinct from ex ante investors.

Ex post investors in period i get security $w_{P,i}(x_i)$ backed by the cash flow x_i from the investment in period i . Ex ante investors and the GP get securities $w_I(x)$ and $w_{GP}(x) = x - w_I(x)$, respectively, backed by the fund cash flow

¹⁵ This result is in contrast with the winner-picking models in Stein (1997) and Inderst et al. (2007), which rely on making the investment manager capital-constrained. Our result is more in line with the empirical finding of Ljungqvist, Richardson, and Wolfenzon (2007), who show that it is common for private equity funds not to use up all their capital.

¹⁶ This assumption is in line with the common covenant in private equity contracts that restricts the amount the GP is allowed to invest in any one deal.

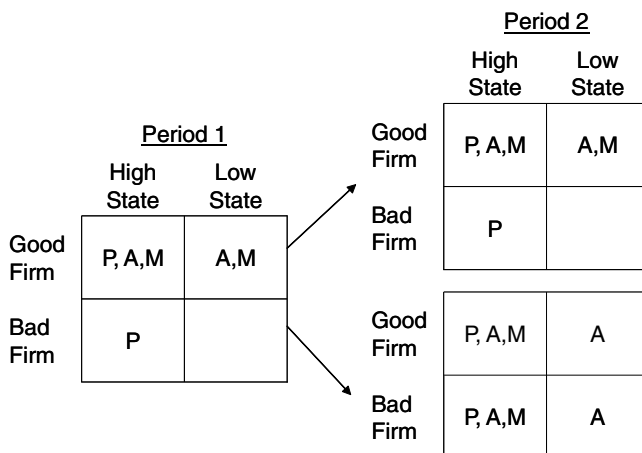

Figure 5. Investment behavior in the pure ex ante (A), pure ex post (P), and the postulated mixed (M) case when ex post financing is possible in the high state.

$x = x_1 - w_{P,1}(x_1) + x_2 - w_{P,2}(x_2)$ (where $w_{P,i}$ is zero if no ex post financing is raised). The fly-by-night condition is now that $w_{GP}(x) = 0$ for all $x \leq 2K$. Finally, we also assume that market participants can observe whether the GP invests in the risk-free asset or a firm, but they cannot write contracts contingent upon this observation.

We show that it is sometimes possible to implement an equilibrium in which the GP invests only in good firms in period 1, only in good firms in period 2 if the GP invested in a firm in period 1, and only in the high state if there was no investment in period 1.¹⁷ As can be seen in Figure 5, this equilibrium is more efficient than the one arising from pure ex ante financing since we avoid investment in the low state in period 2 after no investment has been done in period 1. It is also more efficient than the equilibrium in the pure ex post case, since pure ex post capital raising has the added inefficiencies that no good investments are undertaken in low states, and bad investments are undertaken in high states.

A. Ex Post Securities

We first show that to implement the outcome described earlier, the optimal ex post security is debt. Furthermore, the required leverage to finance each deal should be sufficiently high so that ex post investors are unwilling to lend in circumstances where the risk-shifting problem is severe.

If the GP raises ex post capital in period i , the cash flow x_i can potentially take on values in $\{0, I, Z\}$, corresponding to a failed investment, a risk-free

¹⁷ Note that it is impossible to implement an equilibrium where the GP only invests in good firms over both periods, since if there is no investment in period 1, he will always have an incentive to invest in period 2 whether he finds a good or a bad firm.

investment, and a successful investment. If the GP does not raise any ex post capital, he cannot invest in a firm and saves the ex ante capital K for that period so that $x_i = K$. The security $w_{P,1}$ issued to ex post investors in period 1 in exchange for supplying the needed capital $I - K$ must satisfy a fly-by-night constraint and a break-even constraint

$$w_{P,1}(I) - (I - K) \geq 0 \quad (1)$$

$$w_{P,1}(Z) \geq I - K. \quad (2)$$

Here, the fly-by-night constraint (1) ensures that a fly-by-night operator in coalition with an LP cannot raise financing from ex post investors, invest in the risk-free security, and make a strictly positive profit. The break-even constraint (2) derives from the fact that according to the equilibrium, only good investments are made in period 1, so that the cash flow is Z for certain. Hence, for ex post investors to break even, they only require a payback of at least $I - K$ when $x_i = Z$. It is then immediate that the ex post security that satisfies these two conditions and leaves no surplus to ex post investors is risk-free debt with face value $I - K$.

A parallel argument establishes debt as optimal in period 2 if no investment was made in period 1. The fly-by-night condition stays unchanged, but the break-even condition becomes

$$w_{P,2}(Z) \geq \frac{I - K}{\alpha + (1 - \alpha)p}. \quad (3)$$

This is because when no investment has been made in period 1, the GP will have an incentive to raise money and invest even when he encounters a bad firm in period 2. The cheapest security to issue is then debt with face value $\frac{I - K}{\alpha + (1 - \alpha)p}$.

The last and trickiest case to analyze is the situation in period 2 when there has been an investment in period 1. The postulated equilibrium requires that no bad investments are then made in period 2. Furthermore, since fly-by-night operators are not supposed to invest in period 1, ex post investors know that fly-by-night operators have been screened out. Therefore, we cannot use the fly-by-night constraint in our argument for debt. Nevertheless, as we explain in the Appendix, an application of the Cho and Kreps refinement used in the proof of Proposition 1 shows that we have to have $w_{P,2}(I) \geq I - K$. This is because if $w_{P,2}(I) < I - K$, GPs finding bad firms will raise money and invest in the risk-free security. This in turn will drive up the cost of capital for GPs finding good firms, who therefore have an incentive to issue a more debt-like security. Therefore, risk-free debt is the only possible equilibrium security.

To sum up, debt is the optimal ex post security. It can be made risk-free with face value $F = I - K$ in period 1, and in period 2 if an investment was made earlier. When no investment has been made in period 1, we want to make sure that the amount of capital $I - K$ that the GP has to raise is low enough so that

the GP can invest in the high state, but high enough such that the GP cannot invest in the low state. Using the break-even condition (3), the condition for this is

$$(\alpha_H + (1 - \alpha_H)p)Z \geq I - K \geq (\alpha_L + (1 - \alpha_L)p)Z. \quad (4)$$

We summarize our results on ex post securities in the following proposition.¹⁸

PROPOSITION 4: *With mixed financing, the optimal ex post security is debt in each period. The debt is risk-free with face value $I - K$ in period 1 and in period 2 if an investment was made in period 1. If no investment was made in period 1, and the period 2 state is high, the face value of debt is equal to $\frac{I-K}{\alpha_H+(1-\alpha_H)p}$. The external capital $I - K$ raised each period satisfies*

$$(\alpha_H + (1 - \alpha_H)p)Z \geq I - K \geq (\alpha_L + (1 - \alpha_L)p)Z.$$

If no investment was made in period 1 and the period 2 state is low, the GP cannot raise any ex post debt.

Proof: See Appendix.

B. Ex Ante Securities

We now solve for the ex ante securities $w_I(x)$ and $w_{GP}(x) = x - w_I(x)$, as well as the amount of per-period ex ante capital K . The security payoffs must be defined over the following potential fund cash flows, which are net of payments to ex post investors:

¹⁸ We have restricted the analysis to securities backed by the cash flow from a single deal. It is sometimes possible to implement similar investment behavior with ex post debt that is backed by the whole fund. This is only feasible under several restrictive assumptions, however. First, it is necessary to reduce the ex ante capital because the fund-backed debt issued in the second period is by definition backed by all the ex ante capital from period 1. Second, it has to be possible to contractually restrict the GP from saving ex post capital raised in period 1 for investment in period 2, or else the important state contingency of ex post deal-backed debt will be lost with fund-backed debt. Third, one can show that the GP has to be prohibited from ever issuing deal-backed debt, or else he will always have an incentive to do so in period 2 to dilute the fund-backed debt issued in period 1. Anticipating this, deal-backed debt is the only option also in the first period. Even when these restrictions are imposed, fund-backed debt comes with the disadvantage that the debt raised in period 1 introduces a debt-overhang problem that may make it impossible to raise more debt in period 2 to finance investment. This is not a problem in the particular equilibrium we are focusing on because the debt issued in the first period will be riskless. However, when the first period investment is risky, one can show that deal-backed ex post financing is typically more efficient than fund-backed ex post financing.

Fund Cash Flow x	Investments
0	Two failed investments.
$Z - (I - K)$	One failed and one successful investment.
K	One failed investment.
$2K$	No investment.
$Z - \frac{I-K}{\alpha_H + (1-\alpha_H)p} + K$	One successful investment in period 2.
$Z - (I - K) + K$	One successful investment in period 1.
$2(Z - (I - K))$	Two successful investments.

Note that the first two cash flows cannot happen in the proposed equilibrium, and that the last three cash flows are in strictly increasing order. As opposed to the pure ex ante case, the expected fund cash flow now differs for the case in which there is only one successful investment depending on whether the firm is encountered in the first or second period. This difference occurs because if the good firm is encountered in period 2, the GP is pooled with other GPs who encounter bad firms, so that ex post investors will demand a higher face value before they are willing to finance the investment.

For ease of exposition, we will make the following assumption on the parameter space for the remainder of the paper.

ASSUMPTION 1: $Z \leq \frac{2}{1+\alpha_L+(1-\alpha_L)p}I$.

None of the results depend on Assumption 1, but the assumption simplifies the incentive compatibility conditions.¹⁹ The following lemma provides a necessary and sufficient condition on the GP payoffs to implement the desired equilibrium investment behavior. Just as in the pure ex ante case, it is sufficient to ensure that the GP does not invest in bad firms in period 1.

LEMMA 1: *A necessary and sufficient condition for a contract $w_{GP}(x)$ to be incentive compatible in the mixed ex ante and ex post case is*

$$\begin{aligned}
 & q(\alpha_H + (1 - \alpha_H)p)w_{GP} \left(Z - \frac{I - K}{\alpha_H + (1 - \alpha_H)p} + K \right) \\
 & \geq p[E(\alpha)w_{GP}(2(Z - (I - K))) + (1 - E(\alpha))w_{GP}(Z - (I - K) + K)]. \quad (5)
 \end{aligned}$$

Proof: See Appendix.

The left-hand side of the inequality in Lemma 1 is the expected payoff of the GP if he passes up a bad firm in period 1. He will then be able to invest in period 2 if the state is high (probability q), and will be rewarded if this investment is successful (probability $\alpha_H + (1 - \alpha_H)p$). If the state in period 2 is low, he cannot invest, and will receive a zero payoff because of the fly-by-night

¹⁹ Proofs of all results for the general case are provided in the Internet Appendix.

constraint. The right-hand side is the expected payoff if the GP deviates and invests in a bad firm in period 1. In this case, he will be able to raise debt at face value $F = I - K$ in both periods, since the market assumes that he is investing efficiently. Assumption 1 implies that he only receives a positive payoff if the investment in the first period succeeds, which happens with probability p . If he then finds a good firm in period 2, which happens with probability $E(\alpha)$, he invests and receives payoff $w_{GP}(2(Z - (I - K)))$. If he finds a bad firm, he does not invest, and receives payoff $w_{GP}(Z - (I - K) + K)$.

The incentive compatibility condition (5) shows that it is necessary to give part of the upside to investors to avoid risk-shifting by the GP, just as in the pure ex ante case. The GP stake after two successful investments cannot be too high relative to his stake if he passes up a bad firm in period 1.

To solve for the optimal contract, we maximize the GP's expected payoff subject to the investor break-even constraint, the incentive compatibility condition, the fly-by-night condition, the monotonicity condition, and condition (4) on the required amount of per-period ex ante capital K . The full maximization problem is given in the Appendix. The optimal security design is characterized in the following proposition.

PROPOSITION 5: *The ex ante capital K per period should be set maximal at $K^* = I - (\alpha_L + (1 - \alpha_L)p)Z$. An optimal contract (which is not always unique) is given by*

$$w_I(x) = \min(x, F) + k(\max(x - S, 0)),$$

where $2K^* \leq F \leq S \leq Z - (I - K^*) + K^*$ and $k \in (0, 1]$.

Proof: See Appendix.

The mixed financing contracts are similar to the pure ex ante contracts. As in the pure ex ante case, it is essential for the ex ante investors to receive an equity component to avoid the risk-shifting tendencies of the GP, that is, so that he does not pick bad firms whenever he has invested in good firms or has the chance to do so in the future. At the same time, a debt component is necessary in order to screen out fly-by-night operators.

The intuition for why ex ante fund capital K per period should be set as high as possible is as follows. The higher GP payoffs are, conditional on passing up a bad firm in period 1, the easier it is to implement the equilibrium. The GP only gets a positive payoff if he reaches the good state in period 2 and succeeds with the period 2 investment, so it would help to transfer some of his expected profits to this state from states where he has two successful investments. This is possible to do by changing the ex ante securities, since ex ante investors only have to break even unconditionally. However, ex post investors break even state-by-state, so the more ex post capital the GP has to rely on, the less room there is for this type of transfer.

C. Optimality of Third-Party Financing

A key ingredient of the mixed financing solution is that ex post and ex ante investors be different parties. Conceivably, the contract could have specified that the GP has to raise money from the ex ante investors when raising ex post capital. However, this contract would lead to inefficient behavior on the part of the LPs, since their ex post financing decisions will affect the returns on their ex ante investments. In particular, it will often be optimal for the limited partners to refuse financing in period 2 if no investment was made in period 1. This in turn undermines the GP's incentive to pass up a bad firm in period 1, so that the mixed financing equilibrium cannot be upheld.

To demonstrate this idea formally, suppose that the average project in the high state does not break even

$$(\alpha_H + (1 - \alpha_H)p)Z < I.$$

Now suppose we have some candidate contract between the GP and the LP where the GP has to raise additional financing each period to make an investment. Given the contracting limitations we have assumed throughout, the ex ante contract cannot be contingent on the state of the economy. Therefore, in period 2, the contract would either specify that the LP is forced to provide the extra financing regardless of state, or that the LP can choose not to provide extra financing.

Suppose no investment has been made in period 1, that the high state is realized in period 2, and that the GP asks the LP for extra financing. Note that because of the fly-by-night condition, the GP will ask the LP for extra financing regardless of the quality of the period 2 firm, since otherwise he will earn nothing. If the LP refuses to finance, whatever amount $2K$ that was invested initially into the fund will have to revert back to the LP so as to not violate the fly-by-night condition. If the LP were to agree and finance an investment, the maximal expected payoff for the LP is

$$(\alpha_H + (1 - \alpha_H)p)Z - I + 2K < 2K.$$

Since this is less than what he receives if he were to refuse financing, the LP will choose to veto the investment. Clearly, he will also veto investments in the low state. Thus, there can be no investment in period 2 if there was none in period 1. But then, the GP has no incentive to pass up a bad firm encountered in period 1, so the mixed financing equilibrium breaks down.

This argument shows the benefit of using banks (or some other third party) as a second source of finance. In period 2, it may be necessary to subsidize ex post investors in the high state for them to provide financing. This is not possible unless we have two sets of investors where the ex ante investors commit to use some of the surplus they gain in other states to subsidize ex post investors.

This result distinguishes our theory of leverage from other theories in which debt provides tax benefits (Modigliani and Miller (1963)) or incentive benefits (Jensen (1986)), since those benefits can be achieved without two sets of investors, that is, by the private equity fund also providing the debt financing in buyouts. Also, the result explains why it is inefficient to give LPs the right to

veto individual deals, which is consistent with the typical partnership agreement in which GPs have complete discretion over their funds' investment policies.

D. Feasibility

A shortcoming of the mixed financing equilibrium is that it is not always implementable even when it creates social surplus. This is because it is hard to provide the GP with incentives to avoid investing in bad firms in period 1. If he deviates and invests, not only will he be allowed to also invest in the low state in period 2, but he will be perceived as being a good type in period 2, which means that he can raise ex post capital more cheaply. The following proposition gives the conditions under which the equilibrium is implementable.

PROPOSITION 6: *Necessary and sufficient conditions for the equilibrium to be implementable are that it creates social surplus and that*

$$\alpha_H + (1 - \alpha_H)p > \max \left(\frac{p}{q}, \frac{\alpha_L + (1 - \alpha_L)p}{1 - \frac{I}{Z} + \alpha_L + (1 - \alpha_L)p} \right).$$

Proof: See Internet Appendix.

This proposition implies that the equilibrium can be implemented if the average project quality in high states (i.e., $\alpha_H + (1 - \alpha_H)p$) is sufficiently good, compared to both the overall quality of bad projects (p) and the average project quality in low states ($\alpha_L + (1 - \alpha_L)p$). In other words, if the project quality does not improve sufficiently in high states compared to low states, it will not be possible to implement this equilibrium.

However, there may be other mixed financing equilibria that can be implemented that, although less efficient, can still improve on the pure ex post or pure ex ante financing solutions. For example, suppose pure ex post financing is feasible. Furthermore, suppose that the mixed financing equilibrium above is not implementable. Then, the following mixed financing equilibrium is always implementable (the formal derivation can be found in the Internet Appendix, Proposition 7):

1. Ex ante capital K is as before, but the GP has an incentive to invest in all firms in period 1. Thus, financing is possible only in the high state.
2. In period 2, GPs who did not invest in period 1 only get financing in the high state, and invest in both good and bad firms. GPs who did invest in period 1 get financing in both states, and invest efficiently.

This equilibrium is more efficient than pure ex post financing because GPs who invested in period 1 will invest efficiently in period 2.

There can be other mixed financing equilibria as well, such as ones where the GP plays a mixed investment strategy in the first or second period. In the

interest of brevity we do not characterize them here, but the message is the same: Mixed financing is likely to dominate pure ex post and pure ex ante financing because it combines the internal incentives of the pure ex ante case with the external screening of ex post financing.

V. Interpreting the Model

A. Implications

The model contains a number of predictions for both the structure and actions of private equity funds. Some of these predictions are consistent with accepted stylized facts about the private equity industry, while others are potentially testable in future research.

A.1. Financing

The model provides an explanation for why most private equity investments are done with a combination of ex ante financing, which is raised at the time the fund is formed, and ex post financing, which is raised deal-by-deal. The advantage of ex ante financing is that it allows for pooling across deals, while ex post financing relies implicitly on capital markets taking account of public information about the current state of the economy. In fact, investments financed by the private equity industry typically do rely on both kinds of financing. Most private equity firms pool investments within funds, and base the GP's profit share, the carried interest or "carry," on the combined profits from the pooled investments rather than having an individual carry based on the profits of each deal.²⁰ To complement the equity provided by the fund, buyouts are typically leveraged to a substantial degree, receiving debt from banks and other sources. Similarly, venture deals are often syndicated, with a lead venture capitalist raising funds from partners, who presumably take into account information on the state of the economy and the industry in their investment decision.

A.2. GP Compensation

The model suggests that fund managers will be compensated using a profit sharing arrangement that balances the need to pay the GP for performance (to weed out unskilled "fly-by-night" GPs) with the need to share profits with investors to mitigate excessive risk-taking. The optimal profit sharing arrangements are likely to be somewhat nonlinear, as is illustrated in Figure 3. This

²⁰ As Schell (2006) explains, it was common for private equity funds in the 1970s and early 1980s to calculate carried interest on a deal-by-deal basis. This practice was gradually replaced by a carry on the aggregate return. The reason for the disappearance of the deal-by-deal approach was that it "... is fundamentally dysfunctional from an alignment of interest perspective. It tends to create a bias in favor of higher risk and potentially higher return investments. The only cost to a General Partner if losses are realized on a particular investment are reputational and the General Partner's share of the capital applied to the particular investment." (Schell, 2006, pp. 2.12–2.13.) This observation is very much in line with the intuition of our model.

prediction mimics common practice, in which fund managers receive carried interest, usually of 20% (see Gompers and Lerner (1999a)). In fact, most partnership contracts give managers a nonlinear profit sharing schedule similar to the one that is optimal in the model: Limited partners first receive all the cash flows until they reach a specified level, usually the value of the committed fund capital plus a “preferred return”; then a “General Partner’s Carried Interest Catch Up” region, in which general partners receive 100% of the profits; and finally the profits split 80–20 between the limited and general partners above that region.

A.3. Fund Structure

The model also suggests explanations for commonly observed contractual features of private equity funds. Standard covenants in partnership agreements include restrictions on the fraction of the firm’s capital that can be used to finance an individual deal (see Gompers and Lerner (1996)). This restriction is an essential feature of our equilibrium. If the GP could use the whole $2K$ of fund capital to finance a deal in period 2, the equilibrium would break down because capital markets would no longer limit GPs’ incentives to overinvest.

The model also provides an explanation for why GPs are left with so much discretion over investment decisions, which at first glance may seem to be a cause rather than a solution to agency problems. In fact, we argue that the discretion is necessary for the fund incentive scheme to work. Giving limited partners decision rights over individual deals would lower the expected quality of investments that are undertaken.

A.4. Industry Cycles and the Fund’s Investments

As is seen in Figure 5, there will be investment distortions even in the most efficient financing equilibrium. There is overinvestment in the good state since some bad investments are made, and there is underinvestment in bad states since some good investments get passed up. As a result, the natural industry cycles get multiplied, and private equity investment will exhibit particularly large cyclicity. Moreover, periods when the private equity markets are booming (a high α in the context of the model) should coincide with periods when lenders lend more aggressively and more marginal investments are undertaken. Also, average credit spreads and real interest rates should be negatively related to investment activity, transaction prices, and leverage. These predictions are consistent with recent evidence documenting a strong relation of buyout leverage, pricing, and overall deal volumes with credit market conditions (see Axelson et al. (2008) and Kaplan and Strömberg (2009)).

A.5. LP Rents

In both the pure ex ante financing case and the mixed financing case, investors cannot always be held to their break-even constraint and will sometimes

be left with some rents in equilibrium. This effect occurs even in a competitive fund-raising market. It therefore provides a potential explanation for the Kaplan and Schoar (2005) finding that limited partners sometimes earn predictable excess returns.

A.6. Testable Predictions

The model also provides a number of predictions that have not been tested in the literature. First, our model predicts that returns on private equity investments should be negatively related to overall deal activity. In bad times, some good investments are ignored and in good times, some bad investments are undertaken. Thus, the average quality of investments taken in bad times will exceed that of those taken in good times. Although this prediction has not been formally tested, it is supported by industry folklore and seems broadly consistent with the evidence in Gompers and Lerner (2000) and Kaplan and Stein (1993).²¹ Second, the model has predictions on the investment behavior throughout the life of a private equity fund. In particular, the model implies that an “overhang” of uninvested capital should affect the willingness of GPs to take marginal projects, especially after periods in which they are faced with bad investment opportunities. Finally, the forces in our model are likely to be stronger for GPs where reputational capital has not been developed to alleviate some of the agency problems. Hence, GPs with shorter track records should have more procyclical fund raising and investment, and more countercyclical performance.

B. Does Our Model Explain the Financial Structure of Standard Corporations?

We have chosen to interpret our model as a model of the private equity industry. However, if we relabel the GP as the CEO, and replace the private equity investments with internal firm projects, it seems that we would have a model of internal capital markets. The choice between pure ex ante and pure ex post fund raising, for example, can be interpreted as a choice between setting up a stand-alone firm or a diversified conglomerate. Also, our model provides insights on the dynamic pattern of fundraising we see for standard firms. Firms issue equity relatively seldomly, with the most important equity issues often early in a firm’s life, while debt issues are done much more often and throughout the life of a firm.²² Furthermore, when firms issue equity they tend to raise more money than they need for their immediate investments and spend the

²¹ Also, Kaplan and Schoar (2005) show that private equity funds raised in periods with high fundraising tend to underperform funds raised in periods with low fundraising. Although this finding seems consistent with our model, they do not explicitly look at the performance of individual investments undertaken in hot versus cold markets.

²² Gomes and Phillips (2005) show that public companies in the United States over the period 1995 to 2003 did three times as many debt as equity issues, which is likely to be an underestimate as their debt issues exclude unsyndicated bank loans.

capital over long periods of time, while the proceeds from debt issues are used up much more quickly.²³ This pattern is consistent with our model; we are not aware of other models with a similar prediction.

However, there are (at least) two reasons why we feel the model fits private equity funds better than standard firms. First, standard firms are infinitely lived, and the finite structure is an especially important driver for the optimality of the mixed financing solution. Second, the mixed financing solution relies critically on cash flows between projects being contractually separable. This is less likely to be the case for standard firms where the boundary between projects is less clear and different projects utilize shared resources. Indeed, the existence of cross-subsidization across projects, which is ruled out in private equity contracts, is one reason why resources are allocated to firms in the first place. Finally, debt issues in standard firms often do not contain the restrictions that we have identified as critical, namely, that the debt finance a particular project and that proceeds from a debt issue not be saved for future investments. For these reasons we think that a serious treatment of how *ex ante* and *ex post* financing can be used for standard firms, and how this interacts with the structure of the internal capital market of an organization, deserves a separate and careful analysis that is beyond the scope of this paper.

Still, our model provides some hints about why the contractibility of individual project cash flows coincides with a finite organizational life, as in private equity funds. In the model, a finite life comes with the disadvantage of investment distortions created by end-period gaming. These distortions are minimized by the mixed financing solution we have proposed. For firms where cash flows cannot be separated, the only available solution is pure *ex ante* fundraising, and therefore a limited life comes at a higher cost for these firms. If the firm could choose a longer life, the pure *ex ante* financing solution approaches first-best investment behavior as the fund life goes toward infinity.²⁴ Intuitively, when the fund life is sufficiently long, the GP will be certain that he will eventually encounter enough good investments to provide sufficient internal incentives to avoid all bad ones. Hence, extending the life is more beneficial for a firm where individual project cash flows are not separable.

To explain why private equity funds, on the other hand, choose a finite life, it is obviously not enough to show that the disadvantages are smaller—there needs to be some advantage to outweigh the cost. Our model does not have any such advantage. However, we believe there are several reasons outside the model for choosing a limited life. Probably the most convincing reasons have to do with agency problems between limited partners and general partners. For example, the finite life creates a clear deadline for the GP to show results, and so is an incentive device to make him improve portfolio companies. Also, when there are concerns about the quality of the GP, the finite life of funds provides a mechanism for LPs to evaluate GPs without committing too much capital, and

²³ See Kim and Weisbach (2008) and Julio, Kim, and Weisbach (2008) for evidence on how firms use proceeds from equity issues and debt issues, respectively.

²⁴ We state and prove this result formally in the Internet Appendix (Proposition 8).

a mechanism for GPs to build reputation and increase fund sizes over time.²⁵ Finally, there are mundane reasons such as LP liquidity constraints and tax status considerations that may contribute to explaining the finite life.²⁶ We leave the important question of what exactly drives the choice of life span of an organization, and how this interacts with the contractual environment, for future research.

VI. Conclusion

Private equity firms generally have a common financial structure: They are finite-lived limited partnerships that raise equity capital from limited partners before any investments are made (or even discovered) and then supplement this equity financing with third-party outside financing at the individual deal level whenever possible. General partners have most decision rights and receive a percentage of the profits, which is junior to all other securities. Yet, while this financial structure is responsible for a very large quantity of investment, we have no theory explaining why it should be so prevalent.

This paper presents a model of the financial structure of a private equity firm. In the model, a firm can finance its investments either *ex ante*, by pooling capital across future deals, or *ex post*, by financing deals when the GP finds out about them. The financial structure chosen is the one that maximizes the value of the fund. Financial structure matters because managers have better information about deal quality than potential investors. Our model suggests that a number of contractual features common to private equity funds arise as ways of partially alleviating these agency problems.

However, our model fails to address a number of important features of private equity funds. First, private equity funds tend to be finitely lived; we provide no rationale for such a finite life. Second, our model does not incorporate the role of general partners' personal reputations. Undoubtedly these reputations, which provide the ability for GPs to raise future funds, are a very important consideration in private equity investment decisions and a fruitful topic for future research.

Appendix: Proofs

Proof of Proposition 2: We first show that condition (IC) indeed implements the investment behavior in Figure 4. First, note that since $w_{GP}(x)$ must be monotonic, the GP always invests in good firms regardless of what other investments he has made. It remains to check that the GP does not invest in bad firms in

²⁵ One such explanation for limited fund life is provided by Stein (2005), who develops a model where funds are open-ended rather than closed-ended because of asymmetric information about fund manager ability.

²⁶ For a firm to qualify for pass-through taxation, it has to be legally considered either a limited liability corporation or a limited partnership (as opposed to a standard corporation), and this often entails restrictions on the life span of the firm.

period 2 after investing in a good firm in period 1, and that the GP does not invest in bad firms in period 1. Using $w_{GP}(0) = w_{GP}(I) = w_{GP}(2I) = 0$ from the fly-by-night constraint, the incentive compatibility conditions are

$$w_{GP}(Z + I) \geq (1 - p)w_{GP}(Z) + pw_{GP}(2Z) \tag{A1}$$

$$\begin{aligned} & (E(\alpha) + (1 - E(\alpha))p)w_{GP}(Z + I) \\ & \geq (1 - p)E(\alpha)w_{GP}(Z) + p(1 - E(\alpha))w_{GP}(Z + I) + pE(\alpha)w_{GP}(2Z) \end{aligned} \tag{A2}$$

$$\begin{aligned} & (E(\alpha) + (1 - E(\alpha))p)w_{GP}(Z + I) \\ & \geq ((1 - p)E(\alpha) + 2p(1 - p)(1 - E(\alpha)))w_{GP}(Z) \\ & \quad + (pE(\alpha) + p^2(1 - E(\alpha)))w_{GP}(2Z). \end{aligned} \tag{A3}$$

The first condition ensures that the GP does not invest in a bad firm in period 2 after investing in a good firm in period 1. The two last conditions ensure that the GP does not invest in a bad firm in period 1. The two conditions differ only on the right-hand side, corresponding to the two possible off-equilibrium investment decisions in period 2: only investing in good firms in period 2 after making a bad investment in period 1 (condition (A2)), or investing in all firms in period 2 (condition (A3)).

Subtracting $(1 - E(\alpha))pw_{GP}(Z + I)$ from both sides of condition (A2) and dividing by $E(\alpha)$, we see that it is identical to condition (A1). Rearranging condition (A3), we get

$$w_{GP}(Z + I) \geq \frac{(E(\alpha) + (1 - E(\alpha))p) + (1 - E(\alpha))p}{(E(\alpha) + (1 - E(\alpha))p)}(1 - p)w_{GP}(Z) + pw_{GP}(2Z). \tag{A4}$$

Note that this implies condition (A1), and is therefore a necessary and sufficient condition for incentive compatibility.

We now solve for the optimal contract. We need to solve for optimal values of $w_{GP}(Z)$, $w_{GP}(Z + I)$, and $w_{GP}(2Z)$. We start by establishing the following claims:

CLAIM 1: *Holding $w_{GP}(Z + I)$ fixed, it is without loss of generality to set $w_{GP}(Z)$ as low as possible in an optimal contract: $w_{GP}(Z) = \max(0, w_{GP}(Z + I) - I)$.*

Proof: First note that we must have $w_{GP}(Z) \geq \max(0, w_{GP}(Z + I) - I)$ from monotonicity and limited liability. Suppose, contrary to the claim, that $w_{GP}(Z) > \max(0, w_{GP}(Z + I) - I)$ in an optimal contract. Then we can relax the incentive compatibility constraint by decreasing $w_{GP}(Z)$ without violating (M) or (FBN). The maximand and the break-even constraint are unaffected by this, since $x = Z$ does not happen in equilibrium so that $w_{GP}(Z)$ does not enter the maximand or the break-even constraint. Q.E.D.

CLAIM 2: *Holding the expected payment to investors fixed, it is without loss of generality to set $w_{GP}(Z + I)$ as high as possible: either $w_{GP}(Z + I) = Z - I$ and $w_{GP}(2Z) \geq w_{GP}(Z + I)$, or $w_{GP}(Z + I) < Z - I$ and $w_{GP}(2Z) = w_{GP}(Z + I)$.*

Proof: We show that increasing $w_{GP}(Z + I)$ while decreasing $w_{GP}(2Z)$ such that the maximand and the expected payment to the LP are held constant will relax (IC). Therefore, as long as monotonicity, limited liability, and the fly-by-night conditions are not violated, this will relax the program. (Note that when $w_{GP}(Z + I) = Z - I$ (the maximum payment), or $w_{GP}(2Z) = w_{GP}(Z + I)$, we cannot do this perturbation without violating monotonicity.) First, suppose $w_{GP}(Z) = 0 > w_{GP}(Z + I) - I$. Then, increase $w_{GP}(Z + I)$ and decrease $w_{GP}(2Z)$ to keep the break-even constraint and the maximand constant

$$-dw_{GP}(2Z) = \frac{2E(\alpha)(1 - E(\alpha)) + (1 - E(\alpha))^2 p}{E(\alpha)^2} dw_{GP}(Z + I).$$

This relaxes (IC). Next, suppose $w_{GP}(Z) = w_{GP}(Z + I) - I$. Doing the same perturbation, we show that (IC) is relaxed. Moving all terms to the left-hand side of (IC), the change in the left-hand side as we increase $w_{GP}(Z + I)$ and $w_{GP}(Z)$ and decrease $w_{GP}(2Z)$ to keep the break-even condition constant is equal to

$$\begin{aligned} & 1 - \frac{E(\alpha) + (1 - E(\alpha))2p}{E(\alpha) + (1 - E(\alpha))p}(1 - p) + \frac{2E(\alpha)(1 - E(\alpha)) + (1 - E(\alpha))^2 p}{E(\alpha)^2} p \\ &= \frac{p - (1 - E(\alpha))2p(1 - p)}{E(\alpha) + (1 - E(\alpha))p} + \frac{2E(\alpha)(1 - E(\alpha)) + (1 - E(\alpha))^2 p}{E(\alpha)^2} p \\ &\geq \frac{2E(\alpha)(1 - E(\alpha))}{E(\alpha)^2} p - \frac{(1 - E(\alpha))2p(1 - p)}{E(\alpha) + (1 - E(\alpha))p} \\ &= 2p(1 - E(\alpha)) \left(\frac{1}{E(\alpha)} - \frac{(1 - p)}{E(\alpha) + (1 - E(\alpha))p} \right) \geq 0. \end{aligned}$$

Thus, the incentive compatibility constraint is relaxed.

Using Claims 1 and 2, and the fact that $w_I(x) = x - w_{GP}(x)$, we see that the optimal investor security w_I is given by

$$\begin{aligned} w_I(x) &= x \quad \text{if } x \leq 2I, \\ w_I(Z) &= Z - \max(w_{GP}(Z + I) - I, 0), \\ w_I(Z + I) &= Z + I - w_{GP}(Z + I), \\ w_I(2Z) &= w_I(Z + I) + k(Z - I), \end{aligned}$$

where $k = 1$ if $w_{GP}(Z + I) < Z - I$, and $k \in [0, 1]$ otherwise. Note that this corresponds to the contract in the proposition if we set $F = Z + I - w_{GP}(Z + I)$ and if we also show that we can rule out $k = 0$. We show this now. When $k = 0$, we must have that $w_{GP}(Z + I) = Z - I$ from Claim 2. But then, the LP only holds risky debt with face value $2I$, so he cannot break even. Hence, this cannot be

a feasible solution, and we can disregard contracts where $k = 0$ without loss of generality.

This proves the first part of the proposition. We now show that the equilibrium is always implementable as long as it generates social surplus. Suppose the GP receives the following contract:

$$w_{GP}(Z) = 0, \quad w_{GP}(Z + I) = w_{GP}(2Z) = \varepsilon.$$

For $\varepsilon > 0$, (IC) holds strictly. Making ε small, an arbitrarily large fraction of cash flows can be given to investors, and (M) and (FBN) hold. Therefore, the break-even condition can always be made to hold as long as the equilibrium creates social surplus. Q.E.D.

Proof of Proposition 4: That debt is optimal in period 1 and after no investment in period 2 is shown in the text. It remains to analyze the situation in period 2 where an investment was made in period 1. Under the equilibrium investment behavior, the period 1 investment should have been in a good firm, and all fly-by-night operators should be screened out. Also, if the GP finds a bad firm, he should either not raise financing, or raise financing and invest in the risk-free asset. A necessary condition for this to be incentive compatible is that we either have

$$w_{GP}(Z - (I - K) + K) > 0, \tag{A5}$$

or, if $I - w_{P,2}(I) > K$,

$$w_{GP}(Z - (I - K) + I - w_{P,2}(I)) > 0. \tag{A6}$$

Otherwise, the GP is strictly better off investing in the bad project. Suppose first that $w_{P,2}(I) < I - K$. Then, condition (A6) holds automatically from monotonicity of w_{GP} if condition (A5) holds, and so must always hold. Furthermore, we have to have

$$w_{GP}(Z - (I - K) + I - w_{P,2}(I)) \geq w_{GP}(Z - (I - K) + K),$$

and

$$w_I(Z - (I - K) + I - w_{P,2}(I)) \geq w_I(Z - (I - K) + K),$$

with at least one of these inequalities strict. Thus, the GP and LP individually are weakly better off, and taken as a coalition are strictly better off, raising capital $I - K$ from the ex post investor and investing it in the risk-free security than not raising any money. We therefore assume that the GP will raise money in this situation. Assume that the GP does raise money and invests in the risk-free asset by issuing security $w_{P,2}$ with $w_{P,2}(I) < I - K$. Then, we have to have $w_{P,2}(Z) > I - K$ for ex post investors to break even. But this security does not satisfy the Cho and Kreps intuitive criterion (see the proof of Proposition 1 in the Internet Appendix for a formal definition) because a GP finding a good firm always has an incentive to deviate and issue a security with $w'_{P,2}(Z) = w_{P,2}(Z) - \varepsilon_1$, $w'_{P,2}(I) = w_{P,2}(I) + \varepsilon_2$ for some $\varepsilon_1, \varepsilon_2 > 0$, while a GP who has found a bad

firm is worse off under this deviation. Thus, we have to have $w_{P,2}(I) = I - K$. Since only GPs finding good firms are supposed to invest, we have to have $w_{P,2}(Z) = I - K$. Thus, debt is the only possible security. Q.E.D.

Proof of Lemma 1: To facilitate the exposition of this and the following proofs, define

$$\begin{aligned} x_{BG} &\equiv Z - \frac{I - K}{\alpha_H + (1 - \alpha_H)p} + K, \\ x_{GB} &\equiv Z - (I - K) + K, \quad x_{GG} \equiv 2(Z - (I - K)). \end{aligned} \quad (\text{A7})$$

We will start out assuming that K in condition (4) is set maximal at $K^* = I - (\alpha_L + (1 - \alpha_L)p)Z$, which we verify in the proof of Proposition 5 later. When this is the case, Assumption 1 ensures that the payoff to the fund if the GP makes two investments and one fails is lower than the ex ante capital $2K$:

$$Z - (I - K^*) = Z(1 - (\alpha_L + (1 - \alpha_L)p)) < 2K^*.$$

The fly-by-night assumption then implies that the GP gets no payoff. If the GP invested in a good firm in period 1, he will then pass up a bad firm in period 2 if

$$w_{GP}(x_{GB}) \geq pw_{GP}(x_{GG}). \quad (\text{A8})$$

Note that this also implies that if the GP invested in a bad firm in period 1, he will also pass up a bad firm in period 2:

$$pw_{GP}(x_{GB}) + (1 - p)w_{GP}(K) \geq p^2w_{GP}(x_{GG}).$$

Since $w_{GP}(K) = 0$ from the fly-by-night condition, this reduces to condition (A8). Now consider the GP's investment incentives in period 1. In period 1, it is always optimal to invest in a good project. We must check that the GP does not want to invest in a bad project to sustain the separating equilibrium. The condition for this is

$$q(\alpha_H + (1 - \alpha_H)p)w_{GP}(x_{BG}) \geq E(\alpha)pw_{GP}(x_{GG}) + (1 - E(\alpha))pw_{GP}(x_{GB}). \quad (\text{A9})$$

We now show that condition (A9) implies condition (A8). Condition (A9) can be rewritten as

$$\frac{q(\alpha_H + (1 - \alpha_H)p)}{E(\alpha)}w_{GP}(x_{BG}) - \frac{(1 - E(\alpha))p}{E(\alpha)}w_{GP}(x_{GB}) \geq pw_{GP}(x_{GG}).$$

Since $w_{GP}(x_{BG}) \leq w_{GP}(x_{GB})$ from monotonicity, this implies that

$$\frac{q(\alpha_H + (1 - \alpha_H)p) - (1 - E(\alpha))p}{E(\alpha)}w_{GP}(x_{BG}) \geq pw_{GP}(x_{GG}),$$

which is stricter than condition (A8) since

$$\frac{q(\alpha_H + (1 - \alpha_H)p) - (1 - E(\alpha))p}{E(\alpha)} < 1. \quad \text{Q.E.D.}$$

Proof of Proposition 5: Using the definitions of x_{GG} , x_{GB} , and x_{BG} in (A7), the full maximization problem can now be expressed as

$$\begin{aligned} \max E(w_{GP}(x)) &= E(\alpha)^2 w_{GP}(x_{GG}) + E(\alpha)(1 - E(\alpha))w_{GP}(x_{GB}) \\ &\quad + (1 - E(\alpha))q(\alpha_H + (1 - \alpha_H)p)w_{GP}(x_{BG}), \end{aligned}$$

such that

$$E(x - w_{GP}(x)) \geq 2K \tag{BE}$$

$$q(\alpha_H + (1 - \alpha_H)p)w_{GP}(x_{BG}) \geq p[E(\alpha)w_{GP}(x_{GG}) + (1 - E(\alpha))w_{GP}(x_{GB})] \tag{IC}$$

$$x - x' \geq w_{GP}(x) - w_{GP}(x') \geq 0 \quad \forall x, x' \text{ s.t. } x > x' \tag{M}$$

$$w_{GP}(x) = 0 \quad \forall x \text{ s.t. } x \leq 2K. \tag{Fly-by-night}$$

Note that we assume that the condition (IC) in Lemma 1 is necessary and sufficient to ensure incentive compatibility. It is always necessary, but may not be sufficient if K is not set maximal. Thus, the program aforementioned is a relaxed version of the overall maximization problem. However, if we show that it is optimal to set K maximal in the relaxed program, it must also be optimal in the overall maximization problem, since the programs coincide when K is set maximal.

Proof that K^ is set maximal at $I - (\alpha_L + (1 - \alpha_L)p)Z$:* Suppose contrary to the claim in the proposition that $K < K^*$ at some candidate optimal contract satisfying monotonicity and limited liability. Note that we have to have $x_{BG} > 2K$ for the equilibrium to be feasible, or else the incentive compatibility condition will not be satisfied. Therefore, cash flow states are ordered as

$$x_{GG} > x_{GB} > x_{BG} > 2K > K.$$

Now suppose we set $K' = K + \Delta$ for Δ arbitrarily small. Defining the new cash flow states as x'_{GG} , x'_{GB} , and x'_{BG} , we then have $x'_{GG} = x_{GG} + 2\Delta$, $x'_{GB} = x_{GB} + 2\Delta$, and

$$x'_{BG} = x_{BG} + \Delta \left(1 + \frac{1}{\alpha_H + (1 - \alpha_H)p} \right) > x_{BG} + 2\Delta.$$

We now claim that there is a new contract w'_{GP} satisfying all constraints that gives the investor and the GP the same expected payoffs, but relaxes the incentive compatibility constraint. Hence, the program is relaxed, and this is an improvement, so increasing K is optimal. This contract is given by

$$w_{GP}(K') = w_{GP}(2K') = 0$$

$$\begin{aligned}
 w'_{GP}(x'_{BG}) &= w_{GP}(x_{BG}) + \left(\Delta \left(1 + \frac{1}{\alpha_H + (1 - \alpha_H)p} \right) - B \right) \\
 w'_{GP}(x'_{GB}) &= w_{GP}(x_{BG}) - (B - 2\Delta) \\
 w'_{GP}(x'_{GG}) &= w_{GP}(x_{GG}) - (B - 2\Delta)
 \end{aligned}$$

for some $B \in (2\Delta, \Delta(1 + \frac{1}{\alpha_H + (1 - \alpha_H)p}))$ such that

$$\begin{aligned}
 (B - 2\Delta)(E(\alpha)^2 + E(\alpha)(1 - E(\alpha)) + (1 - E(\alpha))q(\alpha_H + (1 - \alpha_H)p)) \\
 = \Delta(1 - E(\alpha))q(1 - \alpha_H)(1 - p).
 \end{aligned}$$

The last equality ensures that investors break even also with the new contract, since their payoff relative to the old contract (given by $x' - w'_{GP}(x') - (x - w_{GP}(x))$) is now increased by $B > 2\Delta$ in states x_{GG}, x_{GB} , and x_{BG} , which has to cover the extra capital 2Δ they invest plus the loss of one extra Δ in case of a failed firm in period 2. Note that for small Δ , these changes do not violate monotonicity or limited liability. However, the incentive compatibility constraint is weakly relaxed, since $w_{GP}(x_{BG})$ goes up weakly and $w_{GP}(x_{GB})$ and $w_{GP}(x_{GG})$ go down weakly. Q.E.D.

We are now ready to derive the optimal contract. First, note that we must have $w_{GP}(x) = 0$ for all $x \leq 2K^*$ from the fly-by-night condition, so that the only payoffs left to specify are for states $x \in \{x_{BG}, x_{GB}, x_{GG}\}$. We must have $x_{BG} - 2K^* \geq w_{GP}(x_{BG}) > 0$ for the incentive compatibility condition and the fly-by-night condition to be satisfied. First, note that holding $w_{GP}(x_{BG})$ fixed, all contracts in which

$$w_{GP}(x_{GG}) + \frac{1 - E(\alpha)}{E(\alpha)}w_{GP}(x_{GB}) = W$$

for some fixed W are equivalent, since the expected payoff to investors and GPs is the same across such contracts, and since the incentive compatibility condition is equivalent across such contracts. Furthermore, any such W that can be achieved by a monotonic contract $\{w_{GP}(x_{BG}), w_{GP}(x_{GB}), w_{GP}(x_{GG})\}$ can also be achieved by a monotonic contract $\{w_{GP}(x_{BG}), w'_{GP}(x_{GB}), w'_{GP}(x_{GG})\}$ such that

$$\begin{aligned}
 w'_{GP}(x_{GB}) &= w_{GP}(x_{BG}) + (1 - k)(x_{GB} - x_{BG}) \\
 w'_{GP}(x_{GG}) &= w_{GP}(x_{BG}) + (1 - k)(x_{GG} - x_{BG}),
 \end{aligned}$$

for some $k \in [0, 1]$, since setting k equal to zero maximizes W and setting k equals to one minimizes W among all monotonic contracts given a fixed $w_{GP}(x_{BG})$. Hence, it is without loss of generality to restrict attention to contracts of this form. It is easy to check that this corresponds to the contract in the proposition with

$$\begin{aligned}
 w_I(x_{BG}) &= x_{BG} - w_{GP}(x_{BG}) = F, \\
 S &= x_{BG}.
 \end{aligned}$$

What remains to show is that $k > 0$. Note that any increase in k and simultaneous increase in $w_{GP}(x_{BG})$ that leaves the break-even constraint unchanged relaxes the incentive compatibility condition and so is an improvement. Hence, we must have that either $w_{GP}(x_{BG}) = x_{BG} - 2K^*$ or $k = 1$. But then, if $k = 0$, we must have $w_{GP}(x) = x - 2K^*$ for all $x > 2K^*$, so that $w_I(x) \leq 2K^*$ for all x . However, in this case the investor cannot break even, so this cannot be an optimal contract. Q.E.D.

REFERENCES

- Axelson, Ulf, Tim Jenkinson, Per Strömberg, and Michael S. Weisbach, 2008, Leverage and pricing in buyouts: An empirical analysis, Working paper, SIFR.
- Bolton, Patrick, and David S. Scharfstein, 1990, A theory of predation based on agency problems in financial contracting, *American Economic Review* 80, 93–106.
- Cho, In-Koo, and David M. Kreps, 1987, Signaling games and stable equilibria, *Quarterly Journal of Economics* 102, 179–222.
- Diamond, Douglas, 1984, Financial intermediation and delegated monitoring, *The Review of Economic Studies* 51, 393–414.
- Fenn, George, Nellie Liang, and Steven Prowse, 1997, The private equity industry: An overview, in *Financial Markets, Institutions and Instruments Series*, vol. 6, no. 4 (Blackwell Publishers, Boston).
- Gomes, Armando, and Gordon Phillips, 2005, Why do public firms issue private and public securities?, Working paper, University of Maryland.
- Gompers, Paul, and Josh Lerner, 1996, The use of covenants: An analysis of venture partnership agreements, *Journal of Law and Economics* 39, 463–498.
- Gompers, Paul, and Josh Lerner, 1999a, An analysis of compensation in the U.S. venture capital partnership, *Journal of Financial Economics* 51, 3–44.
- Gompers, Paul, and Josh Lerner, 1999b, *The Venture Capital Cycle* (MIT Press, Cambridge).
- Gompers, Paul, and Josh Lerner, 2000, Money chasing deals?: The impact of fund inflows on the valuation of private equity investments, *Journal of Financial Economics* 55, 281–325.
- Inderst, Roman, Holger Mueller, and Felix C. Münnich, 2007, Financing a portfolio of projects, *Review of Financial Studies* 20, 1289–1325.
- Innes, Robert, 1990, Limited liability and incentive contracting with ex ante action choices, *Journal of Economic Theory* 52, 45–67.
- Jensen, Michael C., 1986, Agency costs of free cash flow, corporate finance, and takeovers, *American Economic Review* 76, 323–329.
- Jensen, Michael C., and William H. Meckling, 1976, Theory of the firm: Managerial behavior, agency costs and ownership structure, *Journal of Financial Economics* 3, 305–360.
- Jones, Charles, and Matthew Rhodes-Kropf, 2003, The price of diversifiable risk in venture capital and private equity, Working paper, Columbia University.
- Julio, Brandon, Woojin Kim, and Michael S. Weisbach, 2008, What determines the structure of corporate debt issues?, Working paper, Ohio State University.
- Kandel, Eugene, Dima Leshchinskii, and Harry Yuklea, 2006, VC funds: Aging brings myopia, Working paper, Hebrew University.
- Kaplan, Steven N., and Antoinette Schoar, 2005, Private equity performance: Returns, persistence and capital flows, *Journal of Finance* 60, 1791–1824.
- Kaplan, Steven N., and Jeremy Stein, 1993, The evolution of buyout pricing and financial structure in the 1980s, *Quarterly Journal of Economics* 108, 313–358.
- Kaplan, Steven N., and Per Strömberg, 2009, Leveraged buyouts and private equity, *Journal of Economic Perspectives* 23, 121–146.
- Kim, Woojin, and Michael S. Weisbach, 2008, Motivations for public equity offers: An international perspective, *Journal of Financial Economics* 87, 281–307.

- Laux, Christian, 2001, Limited-liability and incentive contracting with multiple projects, *Rand Journal of Economics* 32, 514–526.
- Ljungqvist, Alexander, Matthew J. Richardson, and Daniel Wolfenzon, 2007, The investment behavior of buyout funds: Theory and evidence, Working paper, NYU.
- Metrick, Andrew, and Ayako Yasuda, 2007, The economics of private equity funds, *Review of Financial Studies* (forthcoming).
- Modigliani, Franco, and Merton H. Miller, 1963, Corporate income taxes and the cost of capital: A correction, *American Economic Review* 53, 433–443.
- Myers, Stewart, and Nicholas Majluf, 1984, Corporate financing and investment decisions when firms have information that investors do not have, *Journal of Financial Economics* 13, 187–221.
- Sahlman, William, 1990, The structure and governance of venture capital organizations, *Journal of Financial Economics* 27, 473–521.
- Schell, James, 2006, *Private Equity Funds. Business Structure and Operations* (Rel. 12). (Law Journal Press, New York).
- Stein, Jeremy, 1997, Internal capital markets and the competition for corporate resources, *Journal of Finance* 52, 111–133.
- Stein, Jeremy, 2005, Why are most funds open-end? Competition and the limits of arbitrage, *Quarterly Journal of Economics* 120, 247–272.